



Svalbardvej 13, DK-5700 svendborg, Danmark, www.dafila.com

**Rack storages with in rack fire protection.
Fire test method for water mist systems.
DFL Nr. 61204-03**

1. Scope:

1.1 The scope of DFL Method 70111-03 is to provide a fire test protocol for test of water mist systems for installation in rack storages for in-rack fire protection and for overhead protection above the racks.

1.2 The test method is used to test the fire suppression system in storage rack fires with different fire loads and fire spread characteristics.

1.2 The test method is suitable for the testing of fire suppression and fire control performances of water based fire suppression systems designed for in-rack fire protection, having a continues agent supply system.

1.3 DFL Method 70111-03 may be applied for the assessments of single suppression systems abilities to control and suppress fires in storage racks. The test method may also be applied for comparing the fire control and fire suppression abilities of different fire protection systems.

1.4 DFL Method 70111-03 may be used for testing of fire suppression and fire control performances of water mist systems and sprinkler systems with open or closed nozzles installed for in-rack fire protection.

1.5 The test method requires that the systems are designed with a uniform fire protection system on all shelves in all racks, and with a uniform fire protection system installed above the top shelves.

1.6 The test method should only be applied to test storage systems for in-rack protection of fuels having fire loads and fire spread less or similar to the fuels used in the tests.

1.7 The systems tested to this fire test protocol should only be installed in storages with the same designs and operating with the same parameters as tested in the fire tests.

1.8 Systems tested to this protocol should be installed with in-rack protection on all shelves on all racks, and distances between racks, and between fuels should not be shorter than th at tested in the fire tests.

2 Principals:

2.1 Rack designs: (Appendix 1)

The test method operates with two rack designs. Racks with closed shelves, and racks with open shelves. Tests conducted with racks having closed shelves do not cover for system inst allation in storages with racks having open shelves.

Tests conducted with racks having open shelves do also cover for system installation in racks with closed (shielded) shelves.

2.2 Rack configurations: (Appendix 1)

The test method operates with two rack configurations. A single rack, and a double rack system. Fire tests conducted with single rack system do not cover for system installation in storages with double rack systems.

Fire tests conducted with double rack system cover also system installation in single rack storages.

2.3 Spacing between racks: (Appendix 1)

The test method describes maximum distance between racks, and the protocol allows the client to specified shorter distances. Systems should not be installed in racks having less spacing between racks than that used in the fire tests.

2.4 Fuels: (Appendix 2)

The test method describes different fuels. Systems should not be installed for protection of Fuels with Fuel Load higher than the fuel load the client has chosen to use for the fire tests.

Systems should not be installed for protection of fuels with fire spread higher than the fuel fire spread used during the test of the system.

Fuel Load / Fire spread	Fire Spread 1 Moderate fire spread	Fire Spread 2 High fire spread
Fuel Load 1 Moderate Fuel Load	Fuel Type 1.1 Cardboard boxes with internal room dividing made of cardboard material, and positioned on wooden pallets	Fuel Type 1.2 Cardboard boxes with internal room dividing made of cardboard material, covered with plastic wrapping foil and positioned on wooden pallets.
Fuel Load 2 High Fuel Load	Fuel Type 2.1 Cardboard boxes with internal room dividing made of cardboard material, with plastic cups in the internal rooms, and positioned on wooden pallets	Fuel Type 2.2 Cardboard boxes with internal room dividing made of cardboard material, with plastic cups in the internal rooms, covered with plastic wrapping foil and positioned on wooden pallets

2.5 Flue spaces between fuels on the rack shelves (Appendix 3)

The test method operates with flue spaces between fuels on the shelves as specified by the client and with the limitations as specified in this test protocol .

2.5.1 Systems should only be installed to protect rack storages where the height of each shelf is less than the height of shelves used in the fire tests.

2.5.2 Systems should only be installed to protect rack storages where the horizontal flue space between pallets is no less than the flue space used during the fire tests.

2.5.3 Systems should only be installed to protect rack storages where the vertical flue spaces between top of fuel to next shelf are no less than the flue space used during the fire tests.

2.6 System parameters.

2.6.1 Systems to be tested shall be installed in accordance with the installation specifications of the client. The installation shall be uniform on all racks and shelves. The system should have identical nozzles and pipe configurations on all shelves. The fire protection system should have a uniform overhead protection system above the top shelves. The fire tests conducted do only cover the design of the protection system which has been tested in the fire tests.

2.6.2 System water pressures and water flows are specified by the client. Fire tests should be conducted with the specified minimum water pressure.

3. **Test hall:**

3.1 The test hall should have an open volume of minimum 3000m³. The test hall ceiling height should be minimum 12m.

3.2 The test hall should be free from air draft.

3.3 The temperature in the test hall should be 20°C ±5°C prior to the tests.

4. **Instrumentation: (Appendix 5)**

4.1 Temperatures should be measured with 0,5mm wire type K -thermocouples and with a sampling time of 2 sec.

4.2 Water flows should be measured with a sampling time of 2 sec.

4.3 Water pressures should be measured at the system inlet and at the most remote point in the pipe system, with a sampling time of 2 sec.

5. **Tolerances:**

ISO Standard 6182-1 Feb. 1994 edition 4:

Length ±2% of nominal value

Volume ±5% of nominal value

Pressure ±3% of nominal value

Temperature ±5% of nominal value

6. **Observations:**

Before, during and after each test the following observations should be made:

Time of ignition

Activation of system

Time when water is discharged from the system

Time to when the system is shot off.

Damages to the fuel package. To be measured and to be vision recorded.

Temperature recordings. To be sampled at least once every 2 sec.

Water flow rates. To be sampled at least once every 2 sec.

Water pressures. To be sampled at least once every 2 sec.

Number of active nozzles. Time of water discharge to be recorded for each nozzle.

Vision recording of the fire scenarios.

7. Procedure and documentation requirements:

A draft copy of the design, installation and operating instruction manual should be furnished for use as a guide in the testing of the fire protection system devices.

- The instructions should reference the limitations of each device and should include:
Description and operating details of each device and all accessory equipment, including identification of extinguishing system components or accessory equipment by part or model no. etc.
- Nozzle design recommendation and limitations.
- Type and pressure rating of pipe, tubing and fittings to be used.
- Equivalent length values of valves, fittings and system components in the system.
- Discharge nozzle limitations, including maximum dimensional and area coverage, minimum and maximum installation height limitations, and nozzle permitted location in the protected volume.
- Details for the proper installation of each device, including all component equipment.
- Reference to the specific types of detection, activation and control panels (if applicable) to be connected to the system, and the installation of such systems, and settings and orientations of detectors.
- Operating pressure range of the system.
- Method of sizing pipe and tubing.
- Recommended orientation of nozzles, tees and the flows through tees etc.
- Maximum differences in operating (flowing) pressure between the hydraulically closest and most remote nozzle or parts of the system.
- Types and limitations of where and for which types of storages, racks and fuels the system are suitable. Geometry limitations. Building material limitations. Interior construction and design limitations. Fire load limitations.

8. Fuel packages: (Appendix 4)

8.1 The fuels should be dry and stored in a dry environment with a temperature of minimum 16°C.

8.2 Fuel Type 1 Fire Spread Class 1:

The fuel packages consist of wooden EU pallets (0,8m x 1,2m x 0,1m) each containing 12 cubic cardboard boxes (0,5m x 0,50m x 0,5m x 3mm) which are closed with adhesive tape. Each cardboard box is divided into 4 layers separated with 3 cardboard sheets (3mm thick). Each layer is separated into 5 x 5 (25) uniform compartments having 3mm thick cardboard walls. Approximate weight of each box: 1,75kg

8.3 Fuel Type 1 Fire Spread Class 2:

The fuel packages consist of wooden EU pallets (0,8m x 1,2m x 0,1m) each containing 12 cubic cardboard boxes (0,5m x 0,50m x 0,5m x 3mm) which are closed with adhesive tape. The whole box array is wrapped with 3 rounds of non fire retarding plastic wrapping foil (LLDPE 20 μ m). Each cardboard box is divided into 4 layers separated with 3 cardboard sheets (3mm thick). Each layer is separated into 5 x 5 (25) uniform compartments having 3mm thick cardboard walls. Approximate weight of each box: 1,75kg

8.4 Fuel Type 2 Fire Spread Class 1:

The fuel packages consist of wooden EU pallets (0,8m x 1,2m x 0,1m) each containing 12 cubic cardboard boxes (0,5m x 0,50m x 0,5m x 3mm) which are closed with adhesive tape. Each cardboard box is divided into 4 layers separated with 3 cardboard sheets (3mm thick). Each layer is separated into 5 x 5 (25) uniform compartments having 3mm thick cardboard walls. Each compartment contains a plastic cup with the bottom in upward position. The geometry of the cups is approximately: \varnothing 85mm x 90mm x 1mm thick. The weight of the plastic cups is approximately: 33 \pm 2 g / each. The plastic cups are made of Polystyrene. Approximate weight of each box: 5 kg

8.5 Fuel Type 2 Fire Spread Class 2:

The fuel packages consist of wooden EU pallets (0,8m x 1,2m x 0,1m) each containing 12 cubic cardboard boxes (0,5m x 0,50m x 0,5m x 3mm) which are closed with adhesive tape. The whole box array is wrapped with 3 rounds of non fire retardant plastic wrapping foil (LLDPE 20 μ m). Each cardboard box is divided into 4 layers separated with 3 cardboard sheets (3mm thick). Each layer is separated into 5 x 5 (25) uniform compartments having 3mm thick cardboard walls. In each compartment is placed a plastic cup with the bottom in upward position. The geometry of the cups are approximately: \varnothing 85mm x 90mm x 1mm thick. The weight of the plastic cups is approximately: 33 \pm 2 g / each. The plastic cups are made of Polystyrene. Approximate weight of each box: 5 kg

8.6 Target Fuel with Fire Spread Class 1:

The target fuel packages consist of wooden EU pallets (0,8m x 1,2m x 0,1m) each containing 12 cubic cardboard boxes (0,5m x 0,50m x 0,5m x 3mm) which are closed with adhesive tape.

8.7 Target Fuel with Fire Spread Class 2:

The fuel packages consist of wooden EU pallets (0,8m x 1,2m x 0,1m) each containing 12 cubic cardboard boxes (0,5m x 0,50m x 0,5m x 3mm) which are closed with adhesive tape.

The whole box array is wrapped with 3 rounds of non fire retardant plastic wrapping foil (LLDPE 20µm).

9. Ignition sources.

9.1 1m² Diesel pool. A 1m² square 10cm± 1cm high pool tray in 2mm + 1 mm steel plates filled with a 5cm water base and 5 litres of diesel oil. The diesel pool is ignited with 0,5 litre of heptanes, which are pored into the diesel pool 15 sec. prior to be ignited with a torch.

9.2 Ignition block: A 0,06m x 0,06m x 0,075m porous fibreboard cube soaked with 120ml heptane and rapped in thin plastic foil. The plastic foil is removed from the top of the ignition cube 15 sec. prior to be ignited with a torch.

10. Storage Racks & targets (Appendix 4)

10.1 Open single rack:

Steel beam frame rack with three open pallet shelves. Minimum rack beam height: 5,5m. Rack width: minimum 1m. Rack length: 4,3m + 0,2m. Shelf beams approximately 0,1m. Vertical distance from floor to lowest pallet: 0,5m. Vertical distance between pallets: maximum 1,9m. The client may specify lower shelf heights.

10.2 Closed single rack:

Rack design as for open single rack (§10.1) with 1mm thick steel plates (1,2m wide) positioned on top of each pallet shelf. The steel plates should cover the full length and width of the pallet shelves.

10.3 Open double rack:

Two open single racks (§10.1) positioned against each other, so that the gab between the stored box surfaces becomes maximum 0,2m. The Client may specify a smaller gab.

10.4 Closed double rack:

Open double rack in accordance with (§10.3) with 1mm thick steel plates (1,2m wide) positioned on top of each pallet shelf. The steel plates should cover the full length and width of each pallet shelf.

10.5 Target wall: The target wall represents an other rack in the vicinity of the rack on fire. The target wall consists of 5m high and 4,5m long frame, which on the side are covered with 3mm thick cardboard sheets. The target wall is positioned to face the rack in a distance of maximum 1,5m. Shorter distances may be specified by the clients.

11. Simulated rack storage set-up: (Appendix 5)

11.1 The setup simulates a rack storage .

11.2 The set-up consists of a storage rack (§10) with a target wall (§10 .5).

11.3 The racks should be positioned in centre below a minimum 10m x 10m ceiling. The ceiling height should minimum be 8m. The client may specify higher ceiling heights.

11.4 The distance from test hall walls to the ceiling should minimum be 2m, and there should minimum be 2m of free space above the ceiling.

11.5 At the start of each fire the temperature in the test hall should be $20\text{ }^{\circ}\text{C} \pm 5\text{ }^{\circ}\text{C}$.

12. Systems to be tested:

12.1 The fire suppression system to be tested should be checked to be in accordance with the specifications from the client.

12.2 The systems should be installed in accordance with the client's specifications.

12.3 No changes or adjustments to the system should be performed during the test scenario, with the exceptions of cleaning of nozzles and filters, and repairs to the system.

12.4 Systems to be tested involve the hydraulic in-rack fire protection system and overhead fire protection system including means of fire detection and activation of the hydraulic fire suppression systems.

13. Pre-burn time prior to system activation:

13.1 Systems with electrical controlled release:

14.1.1 For rack fires, which are ignited with diesel oil pool (§9.1) the pre-burn time systems should be 30 sec before the detection and activation system is to be switched on.

13.1.2 For rack fires, which are ignited with the ignition cube (§9.2) the pre-burn time should be 60 sec. before the detection and activation system is to be switched on

13.2 Systems with glass bulb fire detection and activation:

No pre-burn time prior to glass bulb detection and activation.

14 Specification of system applications.

14.1.1 The client should specify which fire test scenario. The following should be specified:

- Type of rack storage: Single or Double
- Types of shelves: Open or Shielded
- Fuel load: Type 1 or Type 2
- Fuel fire spread: Class 1 or Class 2

14.1.2 The client should specify the distance between ceiling and fuel on racks.

14.1.3 The client should specify the distance between racks in the storage.

14.1.4 The client should specify the vertical and horizontal distances between pallets and fuel on the racks.

15. Fire test scenarios:

15.1 Tests:

15.1.1 One of the two fire tests scenarios (§15.2) or (§15.3) should be conducted with racks with either closed or open shelves. Only one type of fuel with only one fire spread class should be used for each fire test scenario.

15.2 Single rack fire test scenarios:

15.2.1 Fire below single rack:

In a single rack (§10) four fuel package (§8) as specified by the client (§14) are positioned on each of the two lowest shelves. Four target fuel packages (§8) are positioned on the top shelf. The diesel oil pool (§9.1) is positioned on the floor below the centre of the rack.

The target wall (§8) is positioned on front of the rack.

A thermo couple (§4.1) is positioned in the centre of the flue space between the two centre target fuel packages.

15.2.2 Fire on lowest shelf:

In a single Rack (§10) four fuel package (§8) as specified by the client (§14) are positioned on each of the two lowest shelves. Four target fuel packages (§8) are positioned on the top shelf. The ignition cube (§9.2) is positioned up against the cardboard box in the centre of the lower shelf on a 8 cm x 8 cm 2mm thick steel plate, which is attached to the upper surface of the pallet.

The target wall (§8) is positioned on front of the rack.

A thermo couple (§4.1) should be positioned in the centre of the flue space between the two centre target fuel packages.

15.2.3 Fire on top shelf:

In a single Rack (§10) four fuel package (§8) as specified by the client (§14) are positioned on each of the two top shelves.

The ignition cube (§9.2) is positioned up against the cardboard box in the centre of the top shelf on a 8 cm x 8 cm 2mm thick steel plate, which is attached to the upper surface of the pallet.

The target wall (§8) is positioned on front of the rack.

15.3 Double rack fire test scenarios :

15.3.1 Fire below rack:

In a double rack (§10) four fuel package (§8) as specified by the client (§14) are positioned on each shelf on the two lower shelf levels, and four target fuel packages (§8) are positioned on each of the top shelves. The diesel oil pool (§9.1) is positioned on the floor below the centre of the double rack. The target wall (§8) is positioned in front of the rack.

A thermo couple (§4.1) is positioned in the centre of the flue space between the two centre target fuel packages in the flue space between the two racks of the double rack.

The target wall (§8) is positioned on front of the rack.

15.3.2 Fire on lower shelves:

A double rack (§10) with four fuel package (§8) as specified by the client (§14) are positioned on each shelf on the two lower shelf levels, and four target fuel packages (§8) are positioned on each of the top shelf. One ignition cube (§9.2) are positioned up against the cardboard box in the

centre of each of lower shelves on a 8 cm x 8 cm 2mm thick steel plate, which is attached to the upper surface of the pallet. The target rack (§8) is positioned on front of the rack.

A thermo couple (§4.1) is positioned in the centre of the flue space between the two centre target fuel packages in the flue space between the two racks of the double rack.

The target wall (§8) is positioned on front of the rack.

15.3.3 *Fire on top shelves:*

In a double rack (§10) four fuel package (§8) as specified by the client (§14) are positioned on each shelf on the two top shelf levels. One ignition cube (§9.2) is positioned up against the cardboard box in the centre of each top shelf on a 8 cm x 8 cm 2mm thick steel plate, which is attached to the upper surface of the pallet. The target rack (§8) is positioned on front of the rack.

16 Test procedure: Hydraulic fire suppression system:

16.1 General.

16.1 The following fire tests should be conducted at the minimum water pressure with the overhead fire suppression system installed in maximum and minimum height ..

- Fire test below rack. (§15.2.1 or 15.3.1)
- Fire on lower shelf (§15.2.2 or 15.3.2)
- Fire on top shelf (§15.2.3 or §15.3.2)

16.1.2 The fire tests set-up should be in accordance with §1, to §15, and the fire tests should be conducted with pre-burn times in accordance with §9.

16.1.3 The fire test duration time is 15 min. after activation of the hydraulic system for all fire tests.

16.2 Fire test procedures for each fire test:

16.2.1 Prior to each fire test all geometries of importance for the test results of the fire tests should be measured and checked to be in accordance with the specifications of the client and this test protocol. The measurements should be recorded in the test log.

16.2.2 Prior to each fire it should be checked that the fuel load and fire spread class of the fuel packages and the fire spread class of the target fuel packages are in accordance with the clients specification. It should also be checked that all boxes containing plastic cups are positioned so that the opening of all cups point downwards.

16.2.2 Prior to each fire test it should be checked that the fuel package is positioned in accordance with this manual and the clients requests, and that the environmental conditionings are in accordance with §3. Pictures of the full set-up should be taken.

16.2.3 Prior to each fire test it should be checked that the fire suppression system is in accordance with the clients specification and with this fire test protocol § 12, and that the detection and activation system is in a mode, which allows it to be switched on in accordance with § 9.

16.2.4 Prior to each fire test it is checked that at least two stop watches are operating during the fire test, and that the monitoring of temperatures, water pressures, water flows and visual recordings are correctly installed and operating during the fire test. The installation and instruments are recorded.

16.2.5 30 sec. prior to the ignition of the ignition source (§9,1) heptane is poured into the diesel tray, or the plastic foil on top of the ignition cube is removed.

16.2.6 30 sec prior to the ignition of the fire the data logging is started, and 30 sec. countdown from to time of ignition begins.

16.2.6 30 sec. after start of countdown the fire sources is ignited with a torch.

16.2.7 During the fire test the following parameters should be observe and logged:

- Activation times for detection activation system and time to water discharged from the single nozzles and their position.
- Fire spread in the fuel.
- Fire spread to target fuel packages and target rack.
- Temperatures measured on the thermo couple
- Water pressures at the inlets and most remote positions of the hydraulic suppression system.
- Water flow to the hydraulic suppression system.

16.2.8 15min. after the activation of the hydraulic suppression system the system is turned off, and remaining fires are swiftly and gently extinguished with a fire hose.

16.2.9 Hereafter the data sampling is stopped and logged, and pictures are taken of the full test set-up, and the remaining fuel.

16.2.10 Fire spread in the fuel packages, and fire spread to the target fuel packages and target rack is measured in accordance with §16.3.

16.2.11 Damages to the fuel package is calculated in accordance with § 16.4.

16.3 Assessments of fire spread damage:

Fire spread is said to have occurred on a surface if the surfaces are charred from fire in a connected area larger than 10cm².

16.4 Assessments of fire damages to fuel packages:

Fire damages to fuel packages are calculated by the number of internal box cubes, which have been burned, or where the box cube walls are charred from fire.

One internal box cube represents 0,125% damage to a fuel package.

17 Acceptance criteria: (Appendix 8)

17.1 Acceptance criteria are valid for Single & Double Rack Fire Test with open and shielded shelves and for fuel packages with fire load 1 & 2 and fire spread type 1 & 2.

17.2: *Fire below rack(s):*

17.2.1 Fire spread and damages in rack: (§16.3 & 16.4)

Rack level/fuel package	Outer pallet	centre pallet	centre pallet	Outer pallet
Target fuel package (Top level)	No fire spread	No fire spread	No fire spread	No fire spread
Centre level fuel package	No fire spread to end and top surfaces No damage	No fire spread to top surfaces Max: 10% damage	No fire spread to top surfaces Max: 10% damage	No fire spread to end and top surfaces No damage
Low level fuel package	No fire spread to end and top surfaces Max 10% damage	Max: 50% damage	Max: 50% damage	No fire spread to end and top surfaces Max 10% damage

17.2.2. Fire spread to target rack:
No fire spread is allowed.

17.2.3 Temperature in rack:
30 sec. after system activation maximal 300°C (30sec average temperature)

17.2.4 Overhead protection system:
No activation of hydraulic protection system is allowed

17.3 *Fire on lowest rack(s):*

17.3.1 Fire spread and damages in rack: (§16.3 & 16.4)

Rack level/fuel package	Outer pallet	centre pallet	centre pallet	Outer pallet
Target fuel packages	No fire spread	No fire spread	No fire spread	No fire spread
Centre level fuel packages	No fire spread to end and top surfaces No damage	No fire spread to top surfaces Max: 10% damage	No fire spread to top surfaces Max: 10% damage	No fire spread to end and top surfaces No damage
Low level fuel packages	No fire spread to end and top surfaces Max 10% damage	Max: 50% damage	Max: 50% damage	No fire spread to end and top surfaces Max 10% damage

17.3.2 Fire spread to target rack:
No fire spread is allowed.

17.3.3 Temperature in rack:
30 sec. after system activation maximal 300°C (30sec average temperature)

17.3.4 Overhead protection system:
No activation of hydraulic protection system is allowed

17.4 Fire on top rack(s):

17.4.1 Fire spread and damages in rack: (§16.3 & 16.4)

Rack level/fuel package	Outer pallet	centre pallet	centre pallet	Outer pallet
Top level fuel packages	No fire spread to end and bottom surfaces No damage	50% damage	50% damage	No fire spread to end and bottom surfaces No damage
Centre level fuel packages	No fire spread No damage	No fire spread to bottom No damage	No fire spread to bottom No damage	No fire spread No damage
Low level fuel packages				

17.4.2 Fire spread to target rack:

No fire spread is allowed.

Appendix 1

Racks: Single Rack / Double Rack – Open / Closed (Shielded shelves)

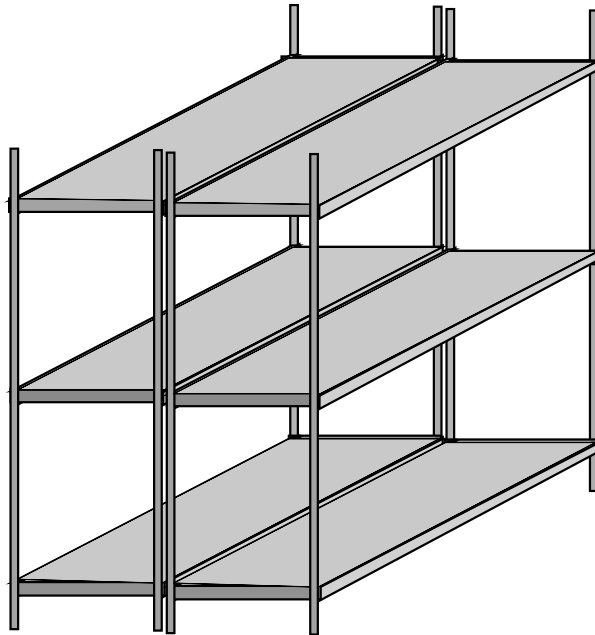
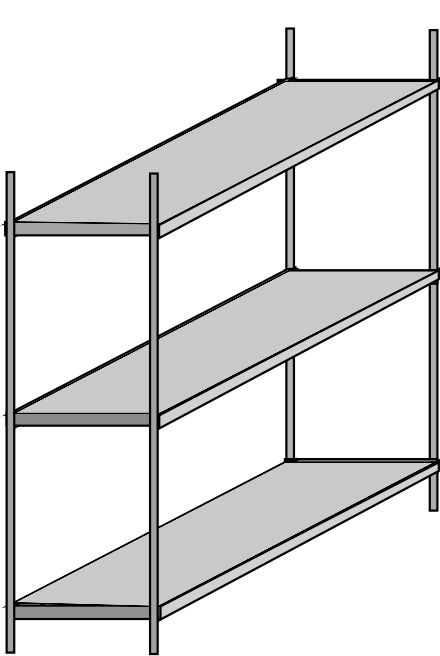
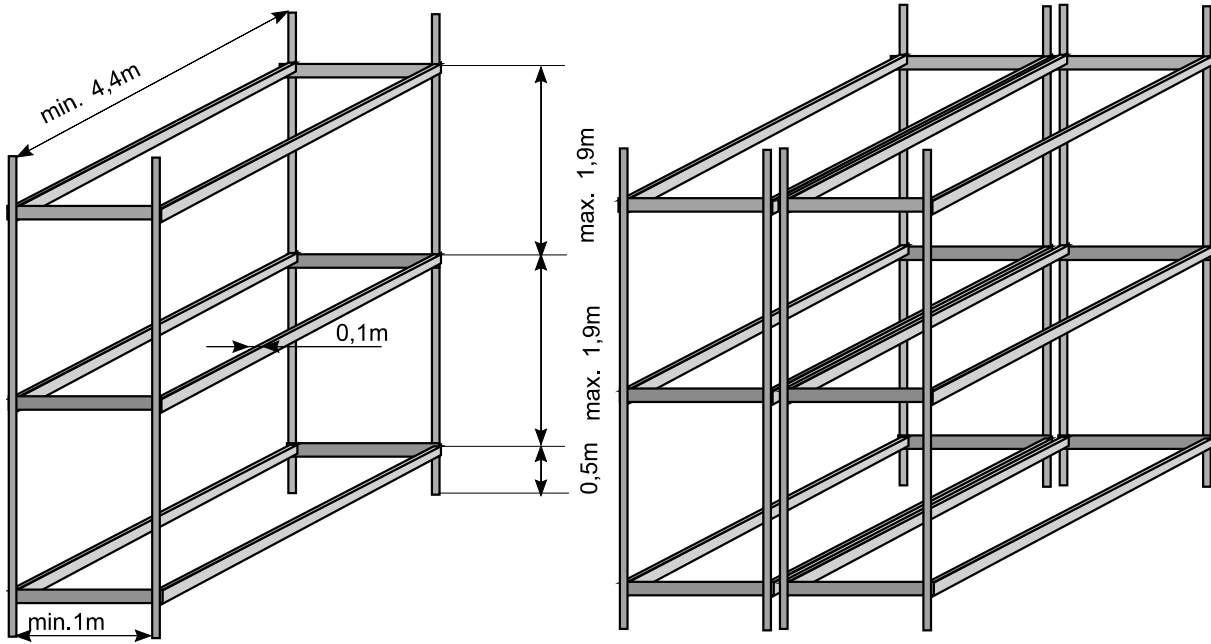

Appendix 2
Fuel Package

Cardboard box fuel type 1

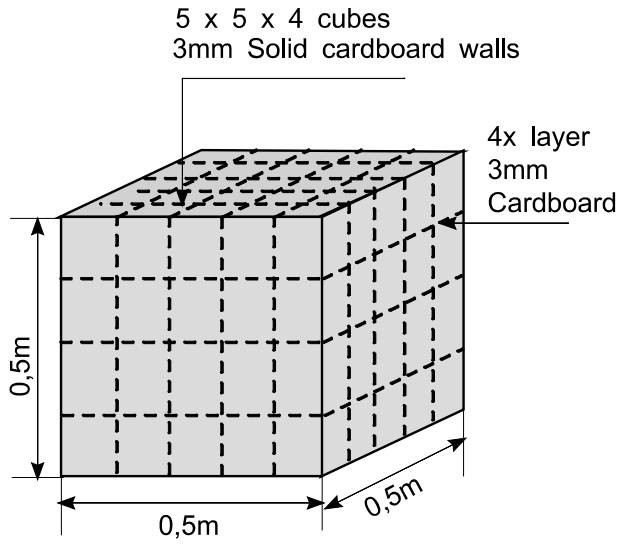

Cardboard box fuel type 2

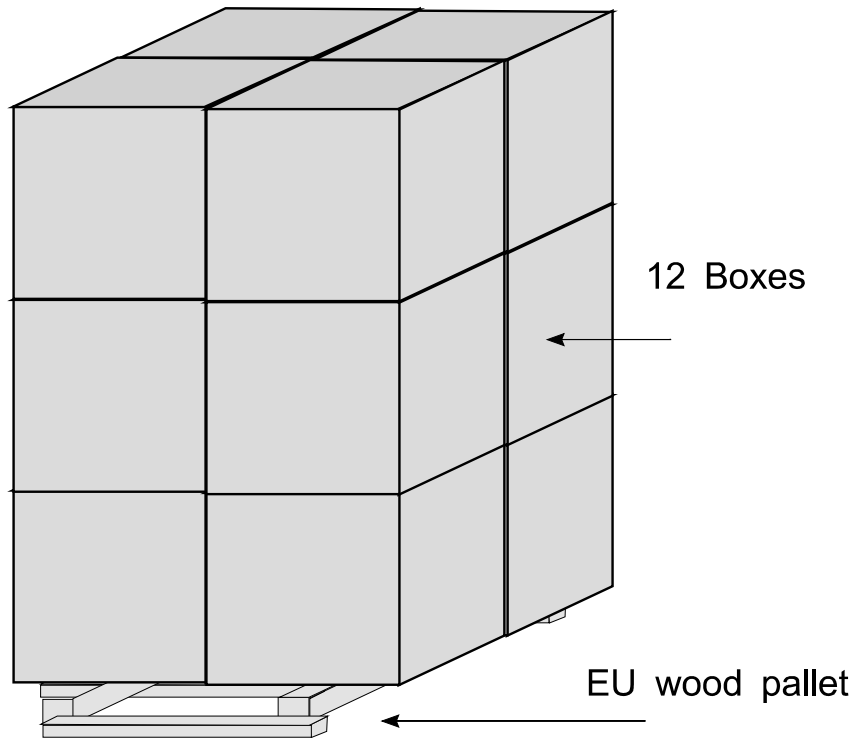
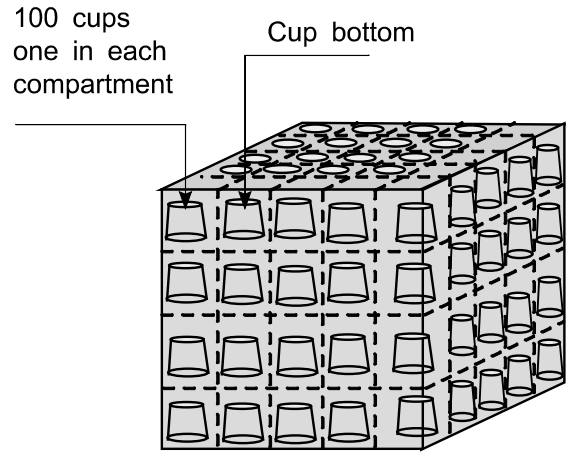

Appendix 3
Storage rack set-up

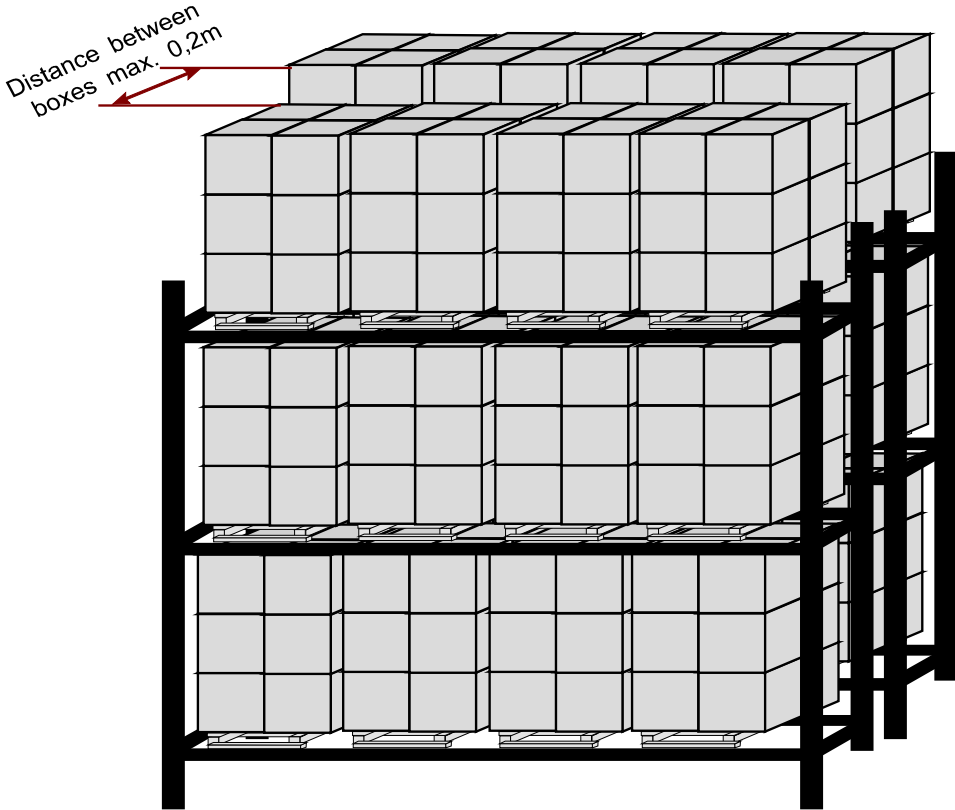
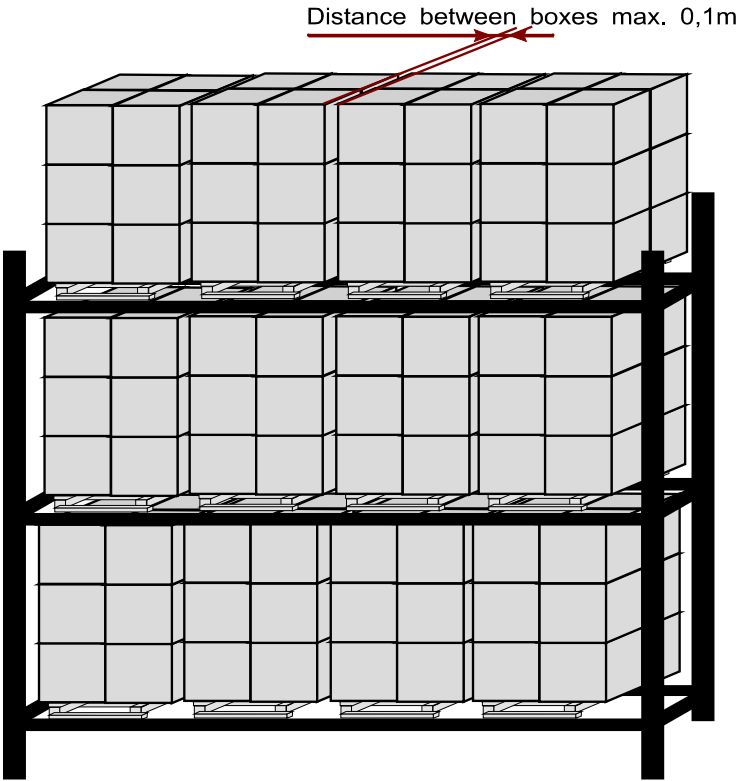

Appendix 4

Single rack:

Thermo couple position:

The thermo couple is positioned on the top rack in space between box a4, a5, b4 and b5. The weld tip of the thermocouple is positioned 0,75m down from the top surfaced of the boxes.

Fire with diesel pool

The 1m² diesel pool is positioned on the floor below box a4, b4, a5, b5.

Fire on lower rack

The ignition cube is positioned on the lower shelf between box a4, a5, b4 b5 against the box side surface near the bottom of the cardboard boxes.

Fire on the top shelf:

The ignition cube is positioned on the top shelf rack between boxes below box a4, a5, b4 b5 against the box side surface near the bottom of the cardboard boxes.

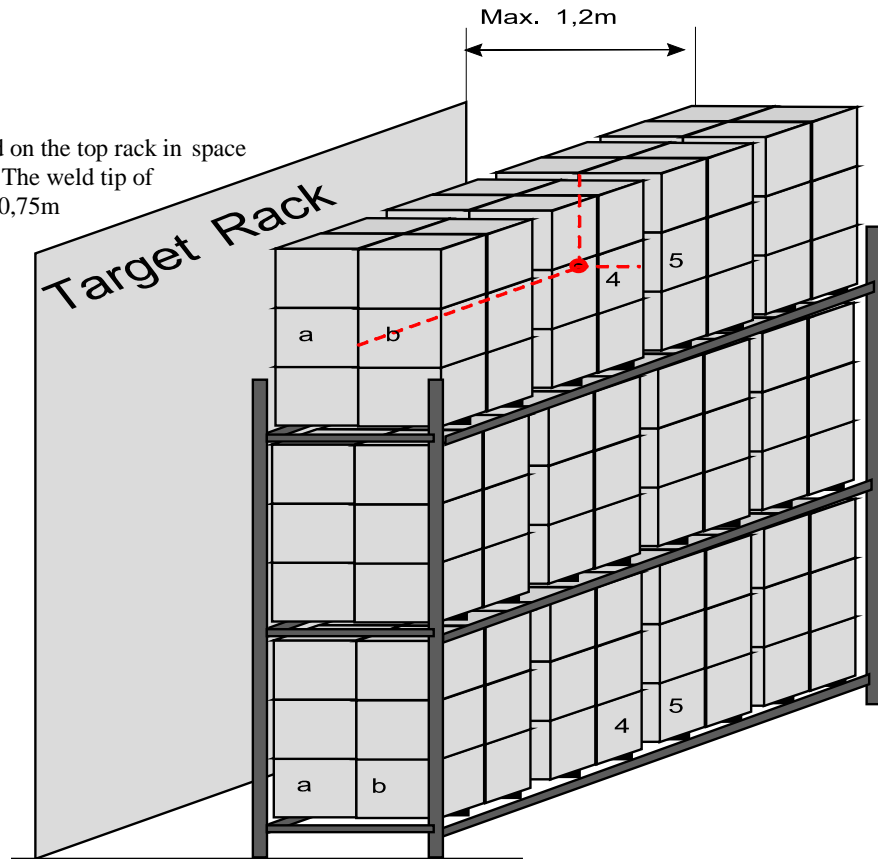

Double rack

Single rack:

Thermo couple position:

The thermo couple is positioned on the top rack in space between box a4, a5, b4 and b5. The weld tip of the thermocouple is positioned 0,75m down from the top surfaced of the boxes.

Fire with diesel pool

The 1m² diesel pool is positioned on the floor below box b4,b5,c4,c5

Fire on lower rack

Two ignition cubes are positioned on both racks on the lower shelves between box a4, a5, b4 b5 against the box side surfaces near the bottom of the cardboard boxes.

Fire on the top shelf:

Two ignition cubes are positioned on both the top shelves rack between the boxes below box a1, a5, b1 b5 against the box side surface near the bottom of the cardboard boxes.

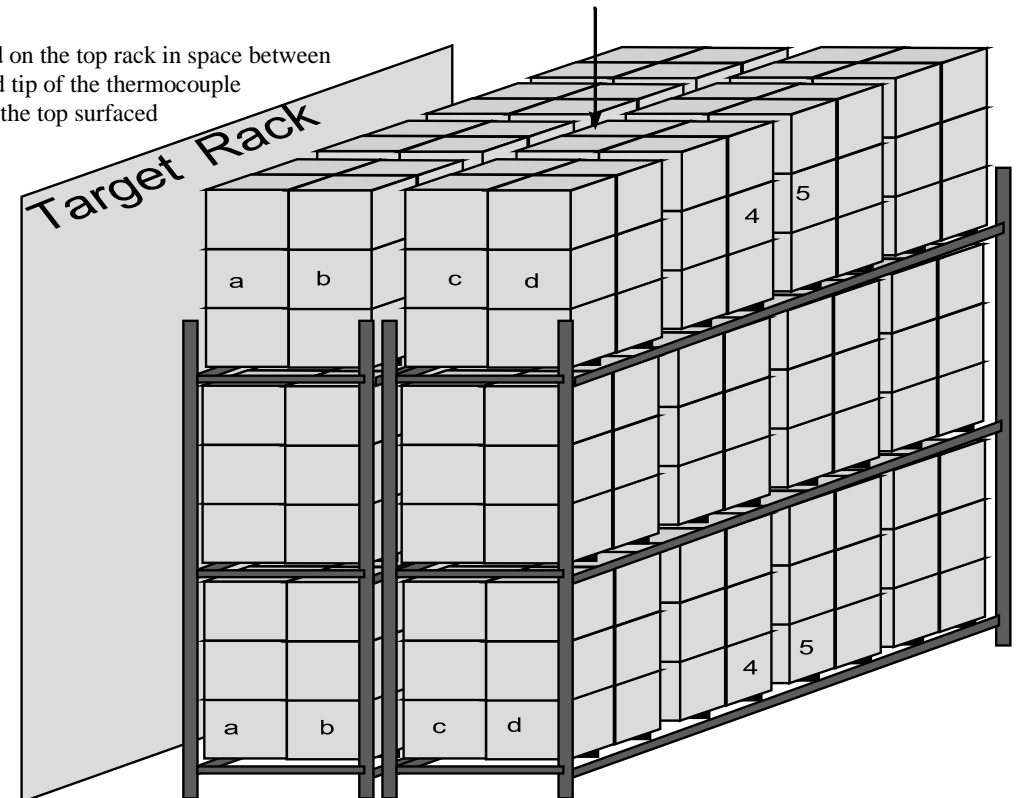

Appendix

Set-up arrangement in test hall

